

	<b>Refrigerated Air Chiller</b>	Rev.	Date	Prepared By	Checked By	Approved By
		A	2020.09.22	WOO.I.H.	JO.S.J.	KIM.H.W.
	<b>Air Cooled Type</b>	B				
		C				
D						
Project Name		-		Model Name		HYD-5CH
<b>SPECIFICATION</b>						
1						
2	Supply Voltage	220V	Inlet Flow Rate	0.5	Nm3/min	
3	Phase	1PH	Inlet Pressure	7	barg	
4	Frequency	60Hz	Inlet Temp.	32	°C	
5	Control use	220V	Inlet Air Condition	Dried Air		
6	Fulid	Compressed Air	Outlet Flow Rate	0.5	Nm3/min	
7	Location	Indoor	Outlet Pressure	6.8	barg	
8	Design Code	Maker STD.	Outlet Temp.	10	°C	
9	Area Class	Non-Hazardous	Pressure Drop	0.2	bar	
10			Design Pressure	14	barg	
11			Design Temperature	70	°C	
12			Ambient Temperature	32	°C	
<b>CONSTRUCTION</b>						
13						
14	Refrigerant	R-134A	Dimension (W x L x H)	244 X 554 X 754	mm	
15	Ref. Compressor Type	Recipro Hemertic	Weight	32	kg	
16	Ref. Compressor Capacity	1/5 HP	Power Consumption	0.3	kW	
17	Condenser Type	Air Cooled	Inlet Connection	15A	PT Female Screw	
18	Condenser Fan Motor	9 W	Outlet Connection	15A	PT Female Screw	
19		1 EA	Drain Connection(Optional)	10A	PT Female Screw	
20	Condenser Fan Size	230 mm	Color (Munsell)	5.7PB 4.1/9.9		
21	Condenser Capacity	1/4 HP		5.7PB 2.9/3.5		
22	Condenser Material	Aluminum & Copper				
23	Heat Exchanger Type	Block				
24	Heat Exchanger Material	Aluminum				
25	Ref. Control Device	Capillary Tube				
26						
27						
<b>STANDRAD FEATURES AND CONTROL</b>						
28						
29	Ref. Compressor	YES	PCB Controller		YES	
30	Air Cooled Condenser	YES	Air Pressure Gauge		NO	
31	Fan Motor	YES	Ref. Pressur Gauge		NO	
32	Fan Controller	YES	Suction Line Accumulator		NO	
33	Ref. High Pressure Switch	NO	Liquid Ref. Receiver		NO	
34	Filter Dryer	YES				
35	Capillary Tube	YES				
36	Heat Exchanger	YES				
37	Temperature Sensor	YES				
38	Hot Gas Bypass Valve	NO				
<b>NOTES</b>						
39						
40						
41						
42						
43						
44						
45						
46						

INLET/OUTLET AIR TEMP.	32°C / 10°C
INLET AIR PRESSURE	7 barg
INLET AIR CONDITION	DRIED AIR
CAPACITY	0.5 Nm <sup>3</sup> /min
IN/OUT CONNECTION	PT 15A
DIMENSION(WXDXH, mm)	244 X 554 X 754
WEIGHT	32 kg
POWER CONSUMPTION	0.3 kW
POWER SUPPLY	220V - 1PH - 60Hz

COOLING AIR DIRECTION

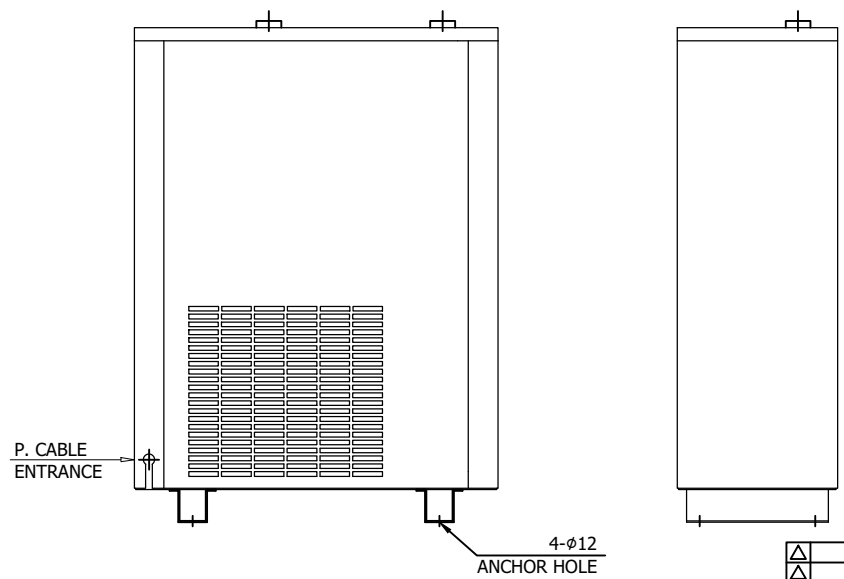
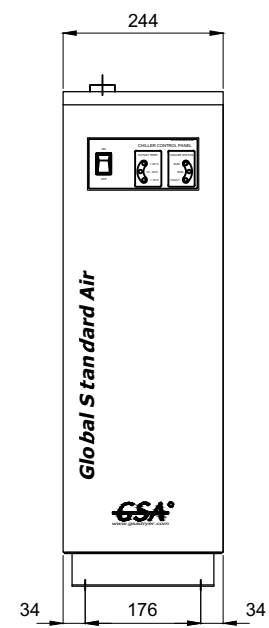
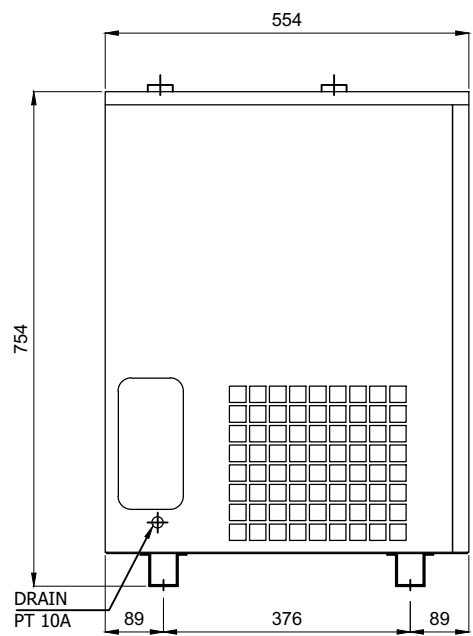
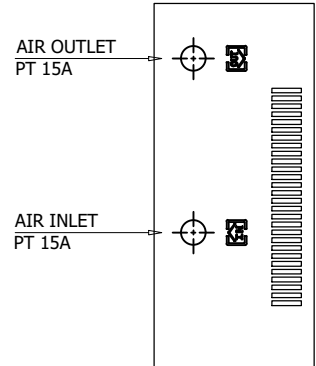
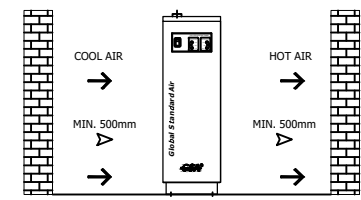

REV. NO.	DATE	DESCRIPTION	ENGR	CHK	APPD	APPD	APPD
1	2020.09.21	ISSUED FOR REFERENCE					
PROJECT							
MANUFACTURER							
 Global Standard Air & Co. Ltd							
TITLE							
OUTLINE DRAWING							
ITEM NO.	HYD-SCH	DWG NO.					REV.
	NONE	GSA-HYD-0005CH-01					1

INLET/OUTLET AIR TEMP.		32°C / 10°C
INLET AIR PRESSURE		7 barg
INLET AIR CONDITION		DRIED AIR
CAPACITY		0.5 Nm <sup>3</sup> /min
8	AUTO DRAIN	OPTION 1
7	HEAT EXCHANGER	5 HP 1
6	CAPILLARY TUBE	- 1
5	FILTER DRYER	1/4" 1
4	FAN CONTROLLER	7~12 barg 1
3	FAN MOTOR	9W 4P #230 1
2	A/C CONDENSER	1/4 HP 1
1	REF. COMPRESSOR	1/5 HP 1
NO.	PART NAME	DESCRIPTION QTY

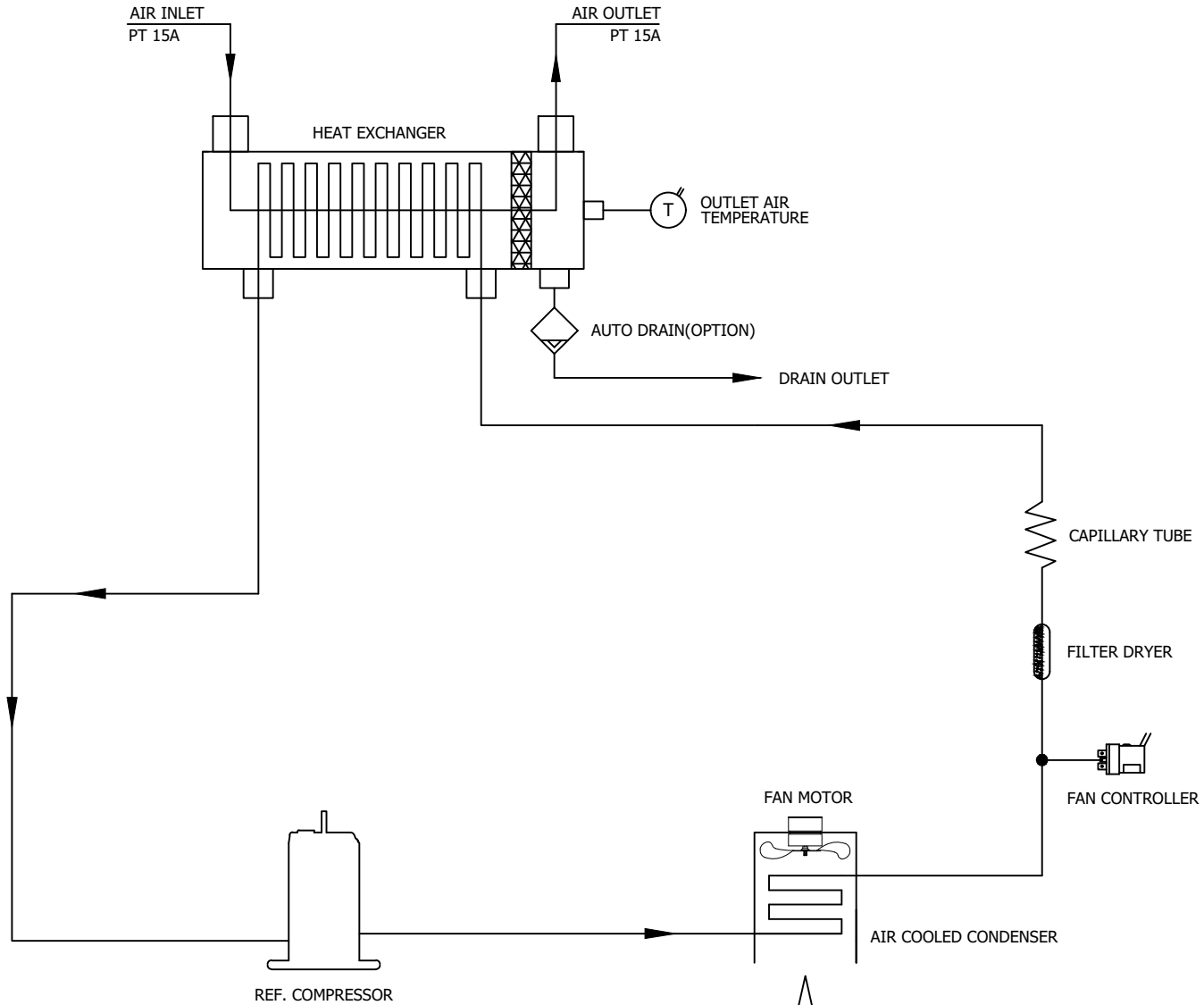

- ← AIR INLET LINE
- AIR OUTLET LINE
- ← REF. LOW PRESS. LINE
- REF. HIGH PRESS. LINE

△									
△									
△									
△									
△	2020.09.21	ISSUED FOR REFERENCE							
REV. NO.	DATE	DESCRIPTION	ENWG	CHK	APPD	APPD	APPD	APPD	APPD
PROJECT									
MANUFACTURER									
 <small>Global Services Africa &amp; Asia</small>									
TITLE									
PIPING & INSTRUMENTATION DRAWING									
ITEM NO.	HYD-SCH	DWG NO.	REV.						
SCALE	NONE	GSA-HYD-0005CH-02	△						

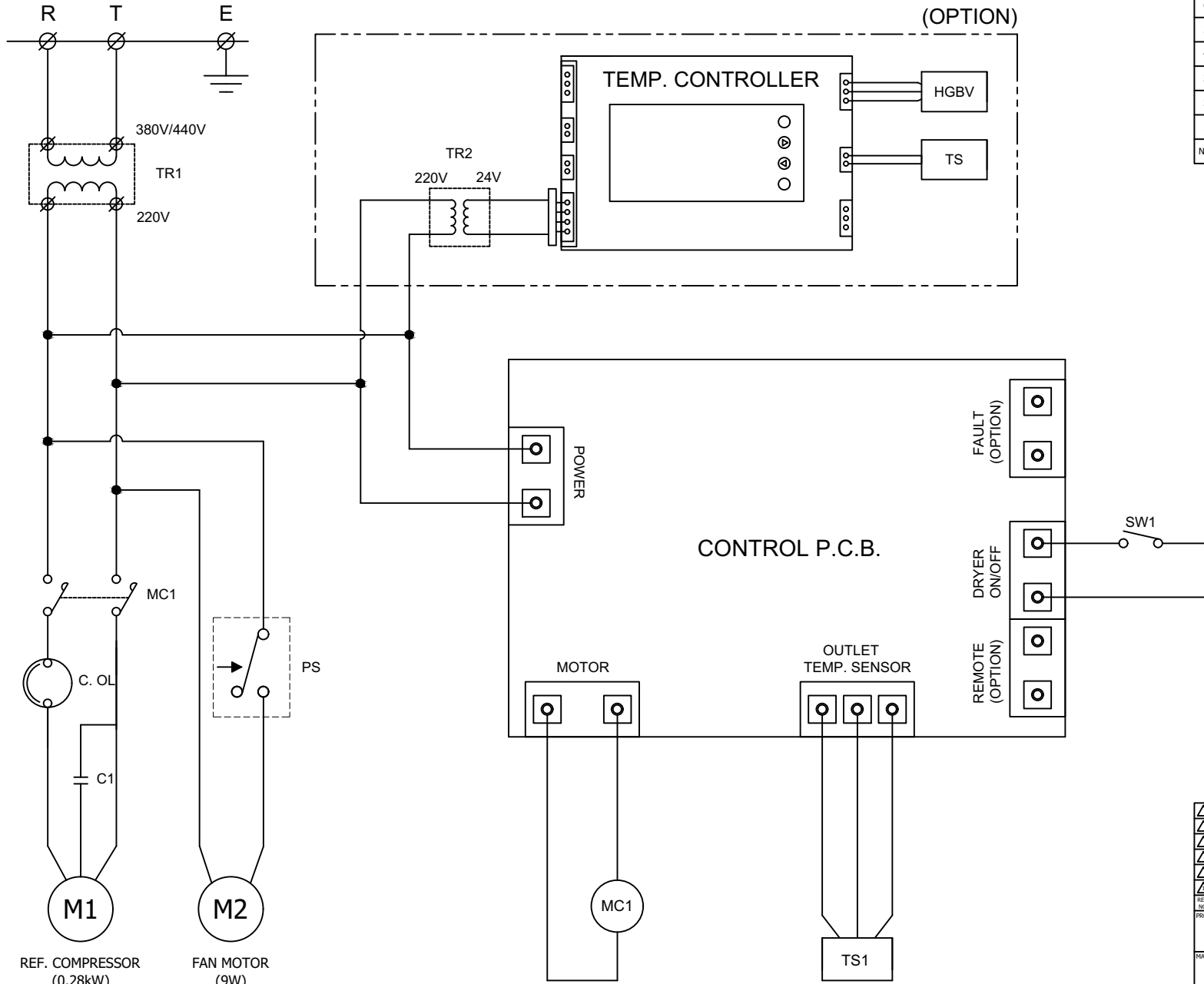

POWER SOURCE  
AC 220/380/440V, 1Ph, 50/60Hz

8	SW1	START/STOP SWITCH
7	TR1	TRANSFORMER(OPTION)
6	TS1	OUTLET TEMP. SENSOR
5	PS	FAN CONTROLLER
4	MC1	MAGNETIC CONTACTOR
3	C1	STARTING CAPACITOR
2	M2	FAN MOTOR
1	M1	REF. COMPRESSOR
NO.	SYMBOL	DESCRIPTION

△									
△									
△									
△									
△	2020.09.21	ISSUED FOR REFERENCE							
REV. NO.	DATE	DESCRIPTION	ENWG	CHK	APPD	APPD	APPD	APPD	
PROJECT									
MANUFACTURER									
 <small>Global Systems of America, Inc.</small>									
TITLE									
WIRING DRAWING									
ITEM NO.	HYD-SCH	DWG NO.	REV.						
SCALE	NONE	GSA-HYD-0005CH-03	△						