

	Refrigerated Air Dryer for High Temp.		Rev.	Date	Prepared By	Checked By	Approved By
			1	2020.09.18	WOO.I.H.	JO.S.J.	KIM.H.W.
	Air Cooled Type		2				
			3				
4							
Project Name		-	Model Name		HYD-400HT		
SPECIFICATION							
1							
2	Supply Voltage	380V	Inlet Flow Rate	56	Nm ³ /min		
3	Phase	3PH	Inlet Pressure	7	barg		
4	Frequency	60Hz	Inlet Temp.	45	°C		
5	Control use	220V	Outlet Flow Rate	56	Nm ³ /min		
6	Fulid	Compressed Air	Outlet Pressure	6.8	barg		
7	Location	Indoor	Outlet Temp.	33±5	°C		
8	Design Code	Maker STD.	Pressure Drop	0.2	bar		
9	Area Class	Non-Hazardous	Outlet Dew Point	2~10	°C		
10			Design Pressure	14	barg		
11			Design Temperature	70	°C		
12			Ambient Temperature	32	°C		
CONSTRUCTION							
13							
14	Refrigerant	R-22	Dimension (W x D x H)	1,000 X 1,900 X 2,015	mm		
15	Ref. Compressor Type	Scroll	Weight	680	kg		
16	Ref. Compressor Capacity	10 HP	Power Consumption	9.7	kW		
17	Condenser Type	Air Cooled	Inlet Connection	100A	KS 10K SO.FF.		
18	Condenser Fan Motor	0.4 kW	Outlet Connection	100A	KS 10K SO.FF.		
19		2 EA	Drain Connection	15A	PT Female Screw		
20	Condenser Fan Size	600 mm	Color (Munsell)	5.7PB 4.1/9.9			
21	Condenser Capacity	15 HP		5.7PB 2.9/3.5			
22	Condenser Material	Aluminum & Copper					
23	Heat Exchanger Type	Block					
24	Heat Exchanger Material	Aluminum					
25	Ref. Control Device	TEV					
26	Temp. Control Device	Hot Gas Bypass Valve					
27	Drain Trap Type	Level Sensor					
STANDRAD FEATURES AND CONTROL							
28							
29	Ref. Press. Transmitter	YES	Ref. Compressor	YES			
30	Ref. Liquid Filter Dryer	YES	Expansion Valve	YES			
31	Overload Relay	YES	Hot Gas Bypass Valve	YES			
32	PCB Controller	YES	Air Cooled Condenser	YES			
33	4.3: TFT LCD	YES	Accumulator with Heat Exchanger	YES			
34	Air Pressure Gauge	YES	Liquid Ref. Receiver	NO			
35	Ref. Pressure Gauge	YES	Oil Separator	YES			
36	Dryer Start/Stop Switch	YES	Circuit Breaker	YES			
37	Moisture Indicator	YES	Ref. Compressor Heater	YES			
38	Drain	YES					
NOTES							
39							
40							
41							
42							
43							
44							
45							
46							

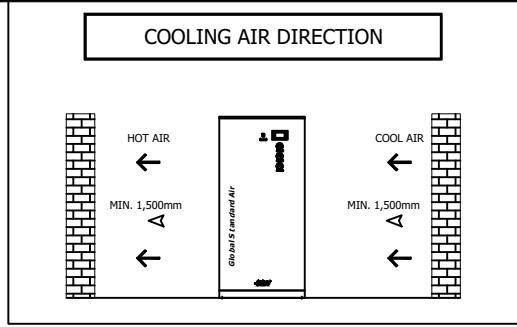

SPECIFICATION	
INLET AIR TEMPERATURE	45°C
AMBIENT TEMPERATURE	32°C
INLET AIR PRESSURE	7 barg
CAPACITY	56 Nm ³ /min
IN/OUT CONNECTION	100A KS 10K SO.FF.
DIMENSION(WXDXH, mm)	1,000 X 1,900 X 2,015
WEIGHT	680 kg
POWER CONSUMPTION	9.7 kW
POWER SUPPLY	380/440V - 3PH - 50/60Hz

△									
△									
△									
△									
△									
△									
REV. NO.	DATE	DESCRIPTION	DWG	CHK	APPD	APPD	APPD	APPD	APPD
2020. 09. 18.		ISSUED FOR REFERENCE							
PROJECT									
MANUFACTURER									
 GSA <small>Global Systems Air & Gas</small>									
TITLE									
OUTLINE DRAWING									
ITEM NO.	HYD-400HT	DWG NO.	GSA-HYD-0400HT-01						
SCALE	NONE								REV. △

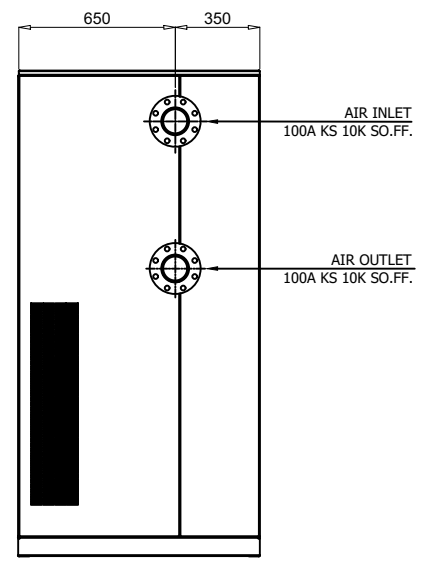
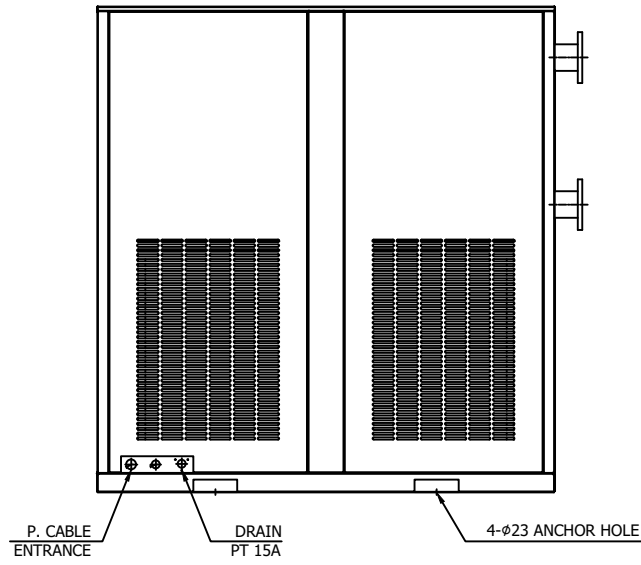
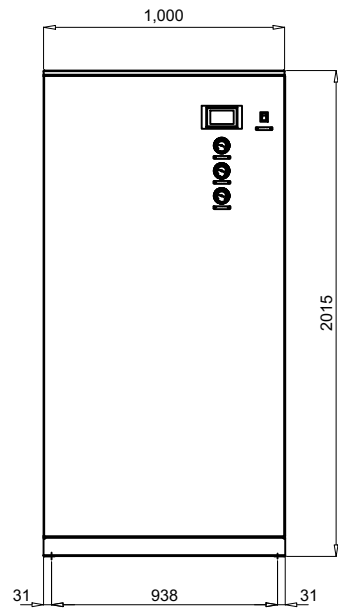
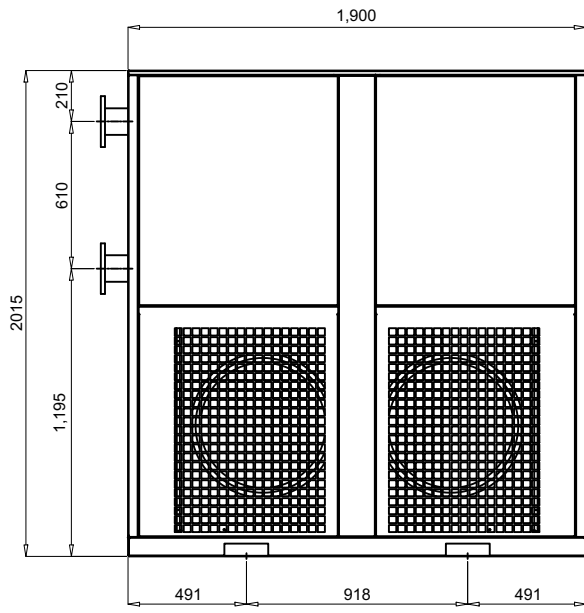
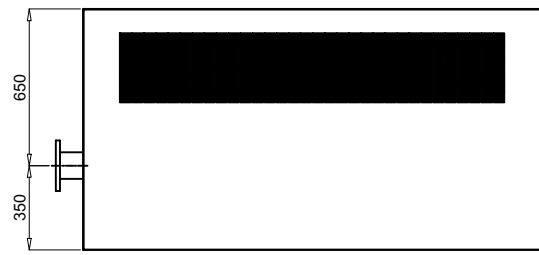

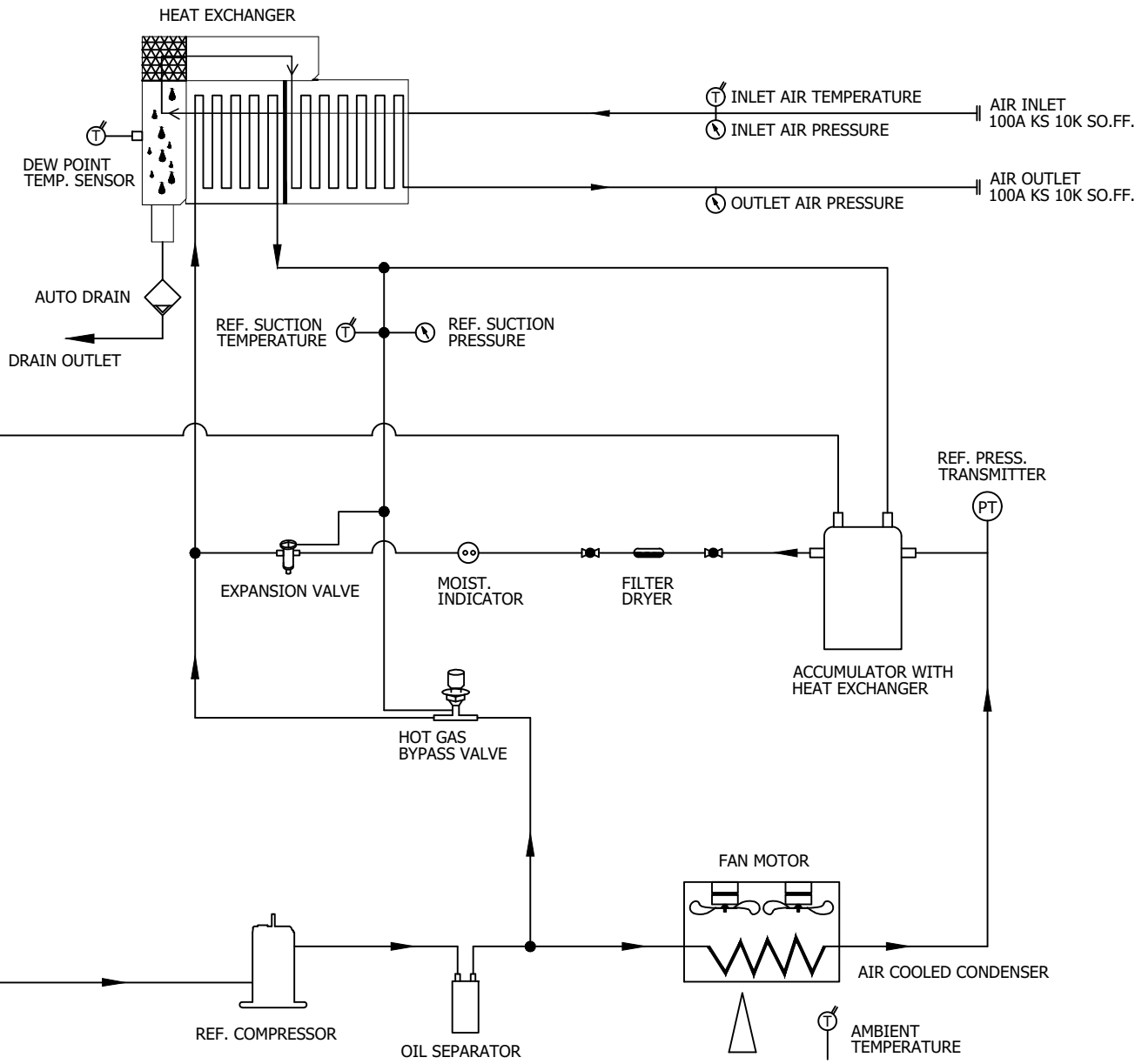
← AIR INLET LINE
 → AIR OUTLET LINE
 ← REF. LOW PRESS. LINE
 → REF. HIGH PRESS. LINE

DEW POINT		2~10°C @ PDP	
INLET AIR PRESSURE		7.0 barg	
INLET AIR TEMPERATURE		45°C	
CAPACITY		56.0 Nm ³ /min	
15	PRESS. GAUGE	OUTLET AIR	1
14	PRESS. GAUGE	INLET AIR	1
13	PRESS. GAUGE	REF. SUCTION	1
12	AUTO DRAIN	PT 15A	1
11	HGBV	-	1
10	HEAT EXCHANGER	400 HP	1
9	EXPANSION VALVE	10 TON	1
8	MOIST. INDICATOR	5/8"	1
7	FILTER DRYER	5/8"	1
6	ACCUMULATOR WITH HEAT EXCHANGER	-	1
5	REF. PRESS. TRANSMIT.	-1 ~ 35 BAR	1
4	FAN MOTOR	0.4KW 6P φ600	2
3	A/C CONDENSER	15 HP (CONDENSING CAPACITY)	1
2	OIL SEPARATOR	-	1
1	REF. COMPRESSOR	10 HP (COOLING CAPACITY)	1
NO.	PART NAME	DESCRIPTION	QTY

△										
△										
△										
△										
△	2020. 09. 18.	ISSUED FOR REFERENCE								
REV. NO.	DATE	DESCRIPTION	DWG	CHK	APPD	APPD	APPD	APPD		
PROJECT										
MANUFACTURER										
 GSA <small>Global Service Automation & Control</small>										
TITLE										
PIPING & INSTRUMENTATION DRAWING										
ITEM NO.	HYD-400HT	DWG NO.	GSA-HYD-0400HT-02				REV.	△		
SCALE	NONE									

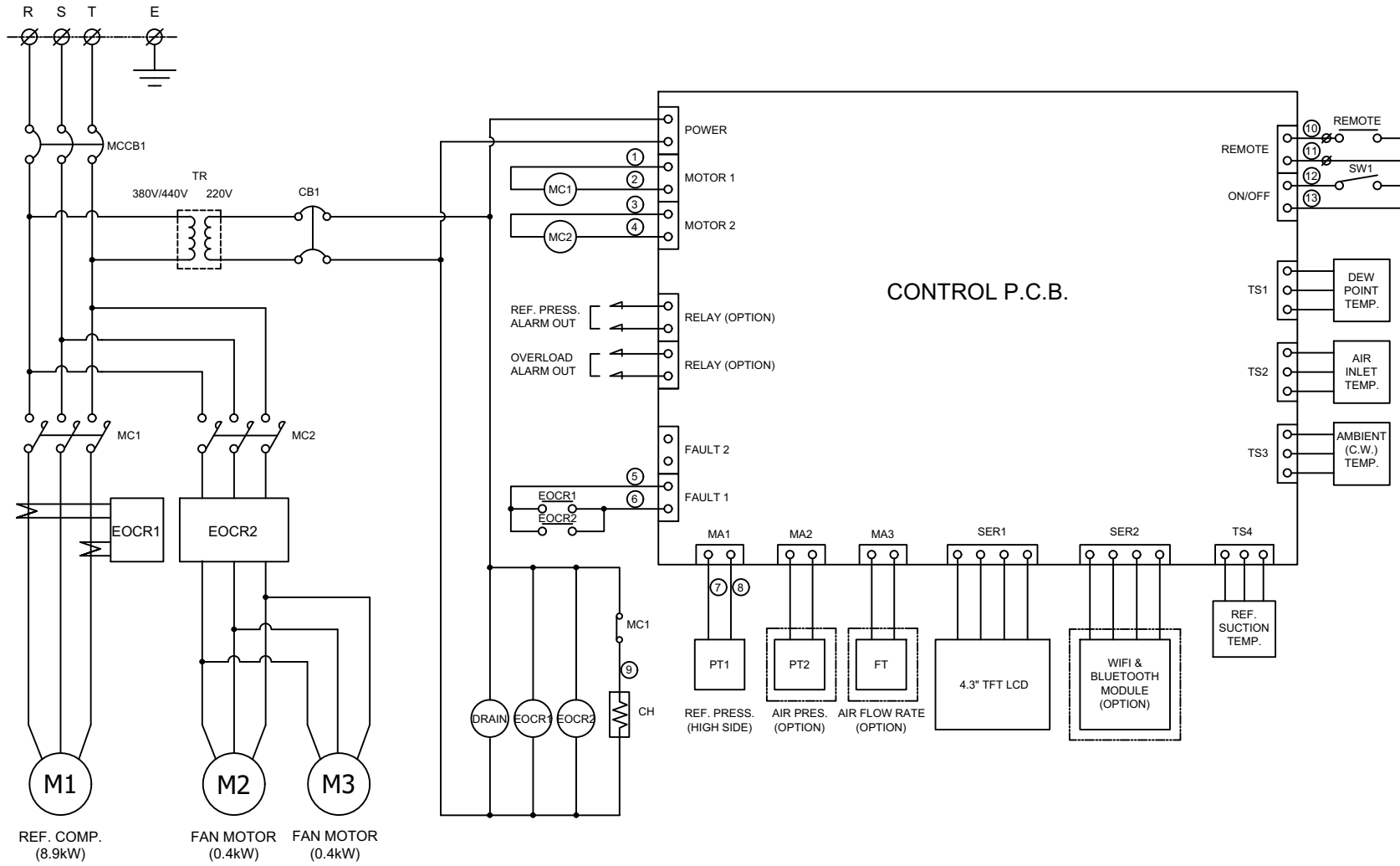

M1
REF. COMP.
(8.9kW)

M2 M3
FAN MOTOR FAN MOTOR
(0.4kW) (0.4kW)

CONTROL P.C.B.

POWER SOURCE
AC 380/440V, 3Ph, 50/60Hz

12	PT1	REF. PRESSURE TRANSMITTER
11	TR	TRANSFORMER
10	SW1	SYSTEM ON/OFF SENSOR
9	CH	REF. COMP. HEATER
8	DRAIN	AUTO DRAIN VALVE
7	TS1 ~ TS4	TEMP. SENSOR
6	CB1	CIRCUIT BREAKER(CTRL)
5	MCCB1	CIRCUIT BREAKER(MAIN)
4	MC1, MC2	MAGNETIC CONTACTOR
3	EOCR1, EOCR2	OVERLOAD RELAY
2	M2, M3	FAN MOTOR
1	M1	REF. COMPRESSOR
NO.	SYMBOL	DESCRIPTION

***REVERSE PHASE WARNING**

Be sure to check the rotation direction of the fan motor and the operating condition of the refrigerant compressor.

- The fan motor must rotate clockwise.
- When the refrigerant compressor is operating, the refrigerant suction pressure will be lowered.

When operating in reverse phase, the refrigerant compressor is damaged.

In case of reverse phase, change the position of 2 wires out of 3 wires of the power supply line.

Problems caused by incorrect power connection are not guaranteed.

REV. NO.	DATE	DESCRIPTION	DWG	CHK	APPD	APPD	APPD
1	2020.09.18	ISSUED FOR REFERENCE					

PROJECT: _____

MANUFACTURER: **GSA**
Global Systems Air & Gas

TITLE: **WIRING DRAWING**

ITEM NO.	HYD-400HT	DWG NO.	GSA-HYD-0400HT-03	REV.	△
SCALE	NONE				